

XRM SERIES INDUSTRIAL INFRARED HEATERS

- HEAVY DUTY U-BEND METAL SHEATH HEATING ELEMENT
- ELECTRIC HEATERS CONVERT ENERGY TO HEAT AT 100% EFFICIENCY
- UL LISTED AND CSA REGISTERED MODELS
- 2.0, 4.5, 6.0 AND 13.5 KW HEAT OUTPUTS AVAILABLE
- VOLTAGES INCLUDE 208, 240, 277, 480 AND 600
- SINGLE OR THREE PHASE OPERATION
- HEATER HAS GASKETED WIRING COMPARTMENT THAT ALLOWS UNITS FOR WASH DOWN
- OPTIONAL SAFETY GRILLES ARE AVAILABLE

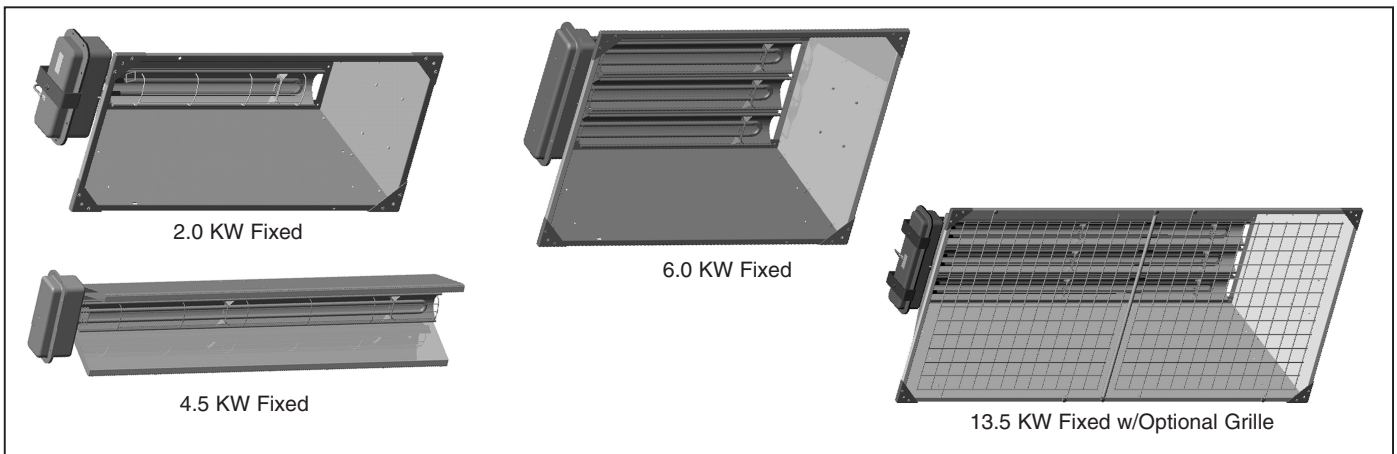

APPLICATIONS

The higher watt density, industrial infrared heaters are designed to provide a rugged source of heat for use in areas where dependence on air movement is impractical. The XRM Series infrared heaters are designed primarily for permanent mounting on the ceiling, but may be used in any orientation. Waste water treatment plants, loading docks, foundries, auto or marine repair facilities, walkways, assembly areas, enclosed smoking areas, repair stations and indoor or outdoor storage areas are just a few examples of where the XRM Series infrared heaters can be used.

DESCRIPTION

The XRM Series infrared heater is an excellent choice for industrial (dirty location) spot heating. Often, a series of spot heat areas can be incorporated within the total area to avoid maintaining a higher ambient temperature throughout the building or room. Comfort levels will depend on the intensity of the wattage output. The XRM Series has four wattage outputs to choose from and starting as low as 2 KW. The construction of the XRM Series heater is simple. Aluminum extruded housing keeps the heating element secure while providing a focal point where a highly polished aluminum reflector emits straight-line heating.

These heaters are constructed with one, two or three metal sheath elements. Patent pending terminal design reduces terminal box temperatures for extended wire life and permits using improved element moisture seal. An extended reflector design constructed of polished aluminum extends over the length of the assembly to provide a uniform heating pattern.

The heating element connects to a gasketed, moisture resistant terminal enclosure. This allows the heater to be washed down, provided the heater is disconnected from the power supply.

HEATER SELECTION CHART

CATALOG NUMBER	WATTS	VOLTS	PHASE	REFLECTOR ANGLE	ELEMENT TYPE	SHIP WT.	AVAIL.				
XRM2081	2,000	208	1	90° Symm	Metal Sheath	18 lbs.	NS				
XRM2021		240					S				
XRM2041		480					NS				
XRM2061		600					NS				
XRM4581	4,500	208	1			90° Symm	Metal Sheath	18 lbs.	NS		
XRM4521		240							S		
XRM4541		480							S		
XRM4561		600							NS		
XRM6083	6,000	208	1 and 3					90° Symm	Metal Sheath	25 lbs.	NS
XRM6023		240	1 and 3								S
XRM6071		277	1								NS
XRM6043		480	1 and 3								S
XRM6063		600	1 and 3	NS							
XRM13583	13,500	208	3	90° Symm	Metal Sheath					55 lbs.	NS
XRM13523		240	3								S
XRM13571		277	1								NS
XRM13543		480	1 and 3			S					
XRM13563		600	1 and 3			1 and 3	NS				

TIP-OVER SWITCH KIT

The tip-over switch kit is available and can be easily added to the heater, whether it is installed permanently or used as a portable unit. The kit de-energizes the heating elements in the event the heater is accidentally knocked over. The kit includes a control circuit transformer, magnetic contactor, tip-over switch and rubber booted ON-OFF toggle switch that are installed in a NEMA 4 enclosure.

POWER DISCONNECT SWITCH KIT

The power disconnect switch kit can be easily mounted to the heater, whether it is installed permanently or used as a portable unit. The disconnect kit consists of a couple liquid tight assembly enclosure including a 3 pole 50 Amp switch, power terminal block and all hardware to mount directly to the heater.

GROUND FAULT DETECTION

Ground fault detection equipment is designed to monitor for any gradual changes in the insulation level due to humidity or mechanical damage as it develops, thus de-energizing the load to prevent arcing type faults, preventing premature element failure and potential fire damage. This unit is wall mounted in a NEMA 4 enclosure and consists of a ground fault sensor, control circuit transformer, magnetic contractor and rubber booted ON-OFF toggle switch.

POWER DISCONNECT, TIP-OVER SWITCH & GROUND FAULT DETECTION

CATALOG NUMBER	DESCRIPTION	KW	Available	SHIP WT.
PDS60050	Power disconnect Kit for Fixed or Portable.	All KW Ratings	S	8 lbs
TOS240	Tip-Over Switch Kit for Fixed or Portable 240V only*	6 or 13.5 KW ratings	NS	15 lbs
TOS480	Tip-Over Switch Kit for Fixed or Portable 480V only*	6 or 13.5 KW ratings	NS	15 lbs
WMGF240	Wall Mounted Ground Fault Detection for 240V - Nema 4 encl.	All KW Ratings	NS	17 lbs
WMGF480	Wall Mounted Ground Fault Detection for 480V - Nema 4 encl.	All KW Ratings	NS	17 lbs

PORTABLE OPTION

The XRM Series 4.5, 6.0 and 13.5 KW infrared "fixed" heaters can be made portable by using one of the optional rollaround cart kits. The cart kit consists of rugged, chrome-nickel plated tubular steel cart and handle. The cart includes large wheels for easy portability and provides for operation in any position when wheeled to any location where electrical power is available.

SAFETY ACCESSORIES

Several safety-related accessories are available for use on the XRM Series infrared heaters.

SAFETY GRILLES, HANGING KITS & ROLLAROUND CART KITS

CATALOG NUMBER	QUANTITY REQUIRED	DESCRIPTION	SHIP WT	AVAIL.
XRMWG2	1	Safety Grille Kit for Permanent installed 2KW heaters	3.0 lbs.	S
XRMWG45	1	Safety Grille Kit for Permanent installed 4.5KW heaters	3.0 lbs.	S
XRMWG60	1	Safety Grille Kit for Permanent installed 6KW heaters	3.5 lbs.	S
XRMWG135	1	Safety Grille Kit for Permanent installed 13.5KW heaters	14.0 lbs.	S
XRMHK	1	Hanging Kit. Includes chain & hooks.	2 lbs	S
XRM45	1	Cart kit includes wheels, legs, handle, & hardware for 4.5kw htrs.	7 lbs	S
XRM60	1	Cart kit includes wheels, legs, handle, & hardware for 6 kw htrs.	8 lbs	S
XRM135	1	Cart kit includes wheels, legs, handle, & hardware for 13.5kw	8 lbs	S

CORD SET FOR ROLLAROUND AND HAND CARRY HEATERS

CATALOG NUMBER	LENGTH (FT.)	CORD SETS FOR ROLLAROUND HEATERS	SHIP WT.	AVAIL.
CS450	25	For use with 4500 Watt heaters 12/3	7 lbs.	S
CS600	25	For use with 6KW & 13.5KW Single Phase 3 Wire 6/3	18 lbs	S
CS603	25	For use with 6KW & 13.5KW Three Phase 4 Wire 6/4	20 lbs	NS

DIMENSIONS

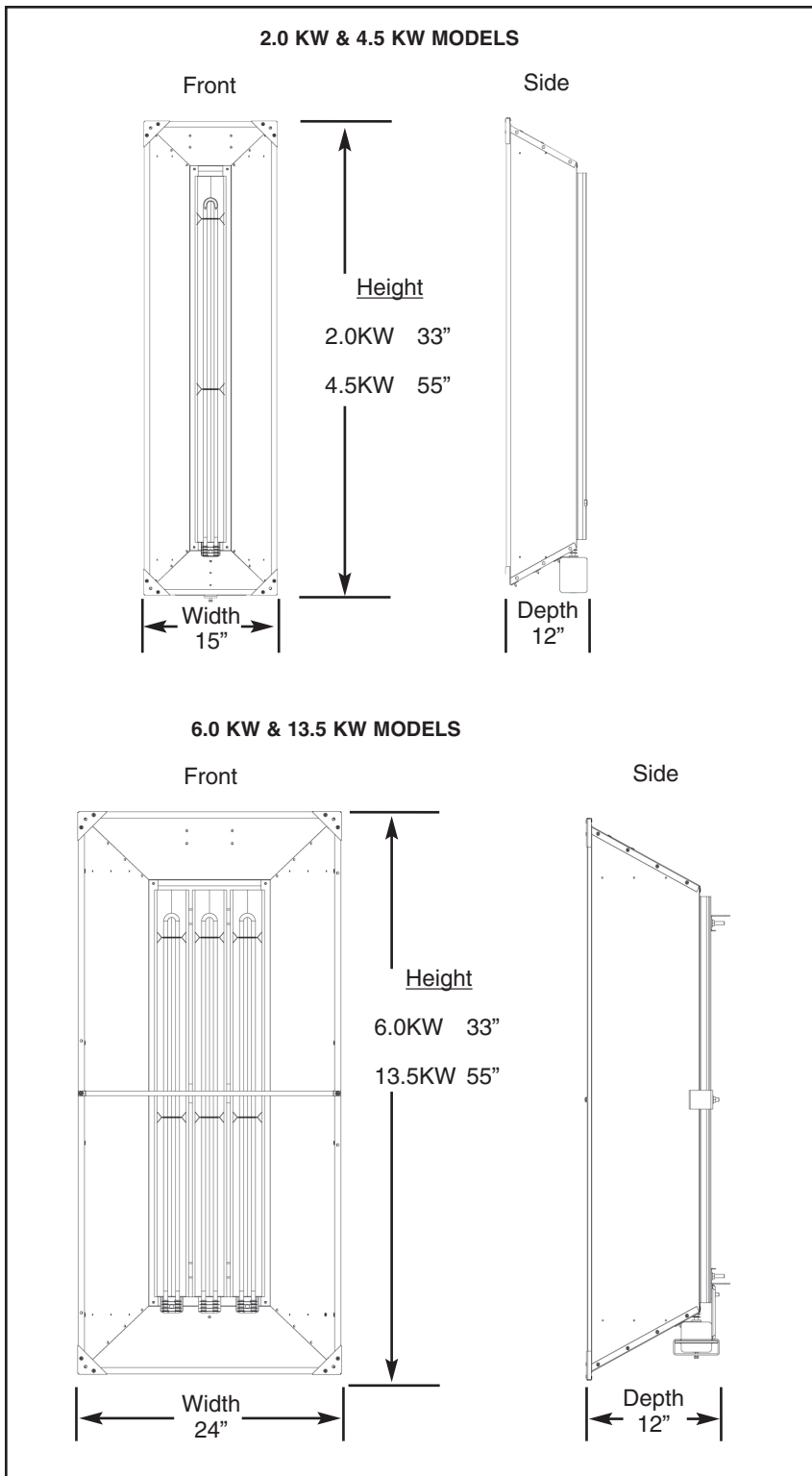

MOUNTING LIMITATIONS:

Minimum spacings:

Ceiling to top of heater is 2 feet.

Wall to sides of heater is 3 feet.

Floor to bottom of heater is 10 feet.

When used as a portable, a minimum of 7 feet to the front of the heater.



A Marley Engineered Products Brand

470 Beauty Spot Rd. E, Bennettsville, SC 29512

Distributed By:

